



***Bucket Elevators  
Painted / Welded Steel Series***



## Capacity Chart

Series	Maximum Capacity	
	Bushels per Hour	Cubic Feet per Hour
"8"	300	375
"11"	1,350	1,688
"18"	2,650	3,312
"24"	3,000	3,750
"30"	4,750	5,938
"36"	7,000	8,750
"42"	15,500	19,375
"48"	16,575	20,740
"48 SX"	20,600	25,745

Capacity based on water level plus 10% cup fill for No. 2 yellow corn at 15% moisture and with a single row of standard CC style cups spaced at nominal cup projection plus 2". Other free flowing materials will have similar capacities. Sticky, very fine, or lightweight materials require special designs. Larger capacities can be achieved by using two or more rows of cups.



## Additional Bucket Elevator Options:

1. Motion monitors.
2. Belt misalignment detection systems.
3. Bearing temperature monitors.
4. Atmospheric vents.
5. Head explosion relief vents.
6. Trunking explosion relief vents.
7. Low speed continuous style buckets - chain or belt mounted.
8. Ceramic chip urethane and other lining materials.
9. Guy cable mounting brackets.
10. Ladder and safety cages.
11. Service platforms – special platforms available for multiple elevator installations.
12. Boot hoppers with magnets.
13. Boot clean-out pans.
14. Self-cleaning gravity boots.
15. Frames for attachment of dust collection equipment.

## *Riley Equipment Manufactures A Complete Line of Bulk Material Handling Equipment . . .*

- Bucket Elevators ■ Distributors ■ Screw Conveyors ■
- Incline Drag Conveyors ■ Super Incline Drag Conveyors ■
- Easy-Flo Drag Conveyors ■ Sur-Flo Drag Conveyors ■ Spouting & Accessories ■ Centrifugal & Continuous Industrial Bucket Elevators ■

*For equipment designed to your specifications contact our Engineering Department.*

## *Riley Equipment, Inc.*

P.O.Box 435

Phone: 812-886-5500  
Fax: 812-886-5515

2205 S. Old Decker Road  
Vincennes, Indiana 47591-0435

Website: [www.rileyequipment.com](http://www.rileyequipment.com)  
E-Mail: [sales@rileyequipment.com](mailto:sales@rileyequipment.com)

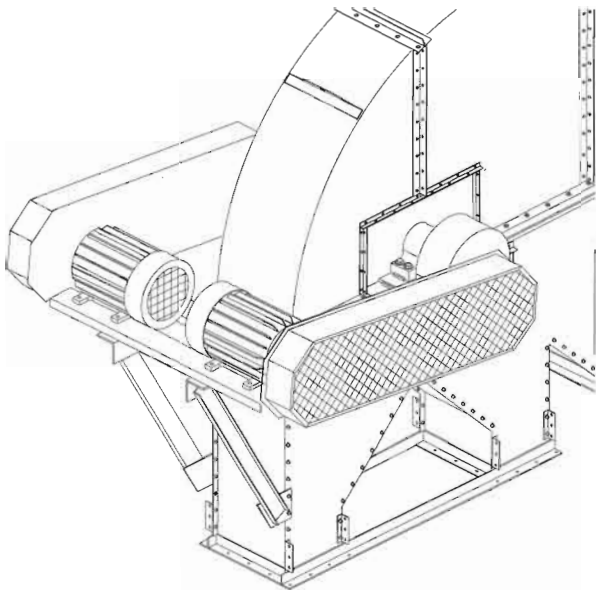

■ Dual Drives

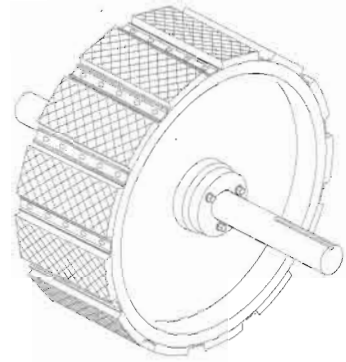

■ Drum Head Pulley with Slide Lagging Standard

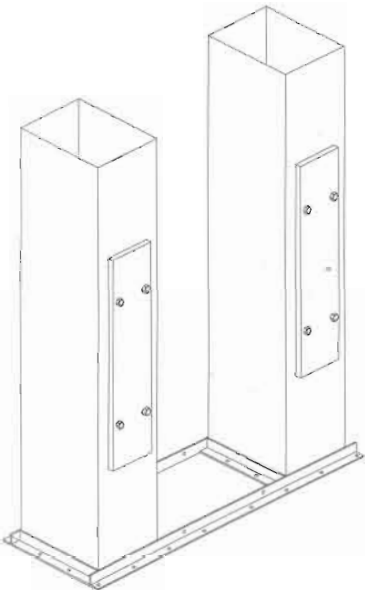

■ Explosion Relief Panels



Riley Equipment, Inc.  
P.O. Box 435  
2205 S. Old Decker Road  
Vincennes, Indiana 47591-0435

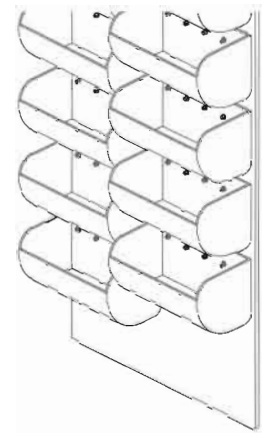

■ Staggered double row of buckets on larger models.

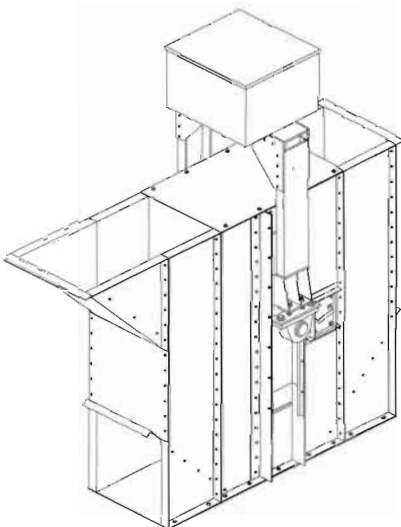

■ Gravity Take-up Boot

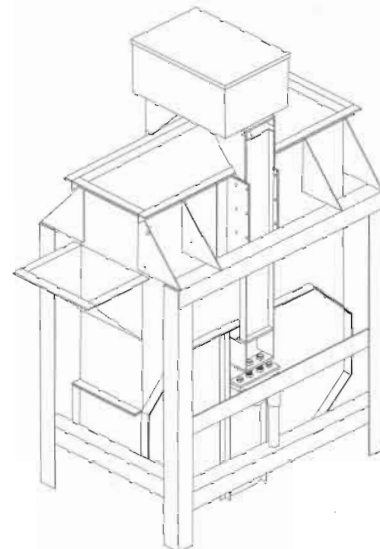

■ Self Cleaning Gravity Take-up Boot

*NOTE: Exact details of some options vary with the size and style of the elevator.*